



# LPGS Series-Gel Battery

## LPGS12-250(12V250Ah)



### Specifications

Rated Voltage	12V	
Nominal Capacity	250Ah (C <sub>10</sub> , 1.80V/cell)	
Dimension	Length	522±2mm (20.6 inches)
	Width	268±2mm (10.6 inches)
	Container Height	220±2mm (8.66 inches)
	Total Height	226±2mm (8.90 inches)
Approx Weight	73.1 Kg (161.2 lbs)	
Terminal	M8	
Container Material	ABS	
Rated Capacity (25°C)	258.0 Ah	(20hr, 12.9A, 1.80V/cell)
	250.0 Ah	(10hr, 25.0A, 1.80V/cell)
	212.5 Ah	(5hr, 42.5A, 1.75V/cell)
	184.5 Ah	(3hr, 61.5A, 1.75V/cell)
	142.4 Ah	(1hr, 142.4A, 1.65V/cell)
Max. Discharge Current	2500A (5s)	
Internal Resistance (25°C)	Approx 2.5mΩ	
Operating Temp. Range	Discharge : -20 ~ 55°C (-4 ~ 131°F)	
	Charge : -20 ~ 40°C (-4 ~ 104°F)	
	Storage : -20 ~ 50°C (-4 ~ 122°F)	
Nominal Operating Temp. Range	25±3°C (77±5°F)	
Cycle Use	Initial Charging Current less than 62.5A. Voltage 14.4V~15.0V at 25°C(77°F)Temp. Coefficient -30mV/°C	
Standby Use	Initial Charging Current less than 62.5A. Voltage 13.5V~13.8V at 25°C(77°F)Temp. Coefficient -20mV/°C	
Effect of temp. to Capacity	40°C (104°F)	103%
	25°C (77°F)	100%
	0°C (32°F)	86%
Self Discharge	LPGS series batteries may be stored for up to 6 months at 25°C(77°F) and then a freshening charge is required. For higher temperatures the time interval will be shorter.	

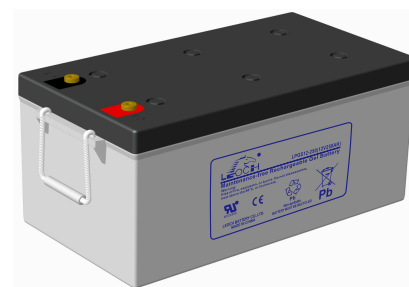

### Layout

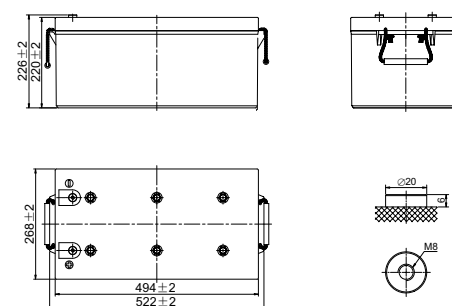

### Constant Current Discharge (Amperes) at 25 °C (77°F)

F.V/Time	10min	15min	20min	30min	45min	1h	2h	3h	4h	5h	6h	8h	10h	20h
1.85V/cell	316.9	269.5	225.4	178.1	135.3	111.9	71.2	55.3	45.5	38.6	33.6	27.4	23.2	12.5
1.80V/cell	399.0	320.8	262.6	205.0	153.5	124.5	77.3	59.4	48.4	41.5	36.1	29.2	25.0	12.9
1.75V/cell	447.4	357.7	288.3	218.5	162.4	131.7	81.1	61.5	50.0	42.5	37.1	29.7	25.3	13.0
1.70V/cell	493.4	386.4	306.5	230.5	170.5	137.5	85.1	63.6	51.5	43.7	37.9	30.1	25.4	13.3
1.65V/cell	/	406.9	322.5	241.4	175.6	142.4	87.4	66.0	53.0	44.7	38.7	30.6	25.6	13.4
1.60V/cell	/	438.7	346.3	256.5	185.7	149.3	90.6	68.3	54.3	45.5	39.5	30.9	26.1	13.5

### Constant Power Discharge (Watts/cell) at 25 °C (77°F)

F.V/Time	10min	15min	20min	30min	45min	1h	2h	3h	4h	5h	6h	8h	10h	20h
1.85V/cell	589.8	506.7	428.1	341.3	261.2	216.9	138.6	108.1	89.1	75.9	66.4	54.3	46.1	24.9
1.80V/cell	734.5	595.7	491.8	387.9	294.2	240.0	149.8	115.5	94.4	81.3	70.9	57.7	49.6	25.6
1.75V/cell	809.9	655.4	534.4	410.0	308.5	252.6	156.5	119.3	97.3	83.1	72.7	58.5	50.0	25.8
1.70V/cell	871.5	697.0	563.0	429.4	322.1	262.6	163.6	123.1	100.0	85.0	74.1	59.3	50.2	26.3
1.65V/cell	/	726.9	586.8	445.6	329.2	270.2	167.1	127.2	102.6	86.7	75.5	60.0	50.6	26.5
1.60V/cell	/	770.7	623.2	469.6	345.8	281.7	172.4	131.0	104.6	88.1	76.9	60.7	51.4	26.7



# LPGS Series-Gel Battery

## LPGS12-250(12V250Ah)



### Applications

- Communication power supply
- Engine starting
- Pump systems
- Alarm installations
- Marine and power stations

### General Features

- Adopted advantage AGM-GEL technology
- Operation temperature  $-20\sim 55^{\circ}\text{C}$
- $\leq 3\%$  Self discharge @ $25^{\circ}\text{C}$

### Standards

- IEC 60896 Certified
- Classified as "Long Life" according to Eurobat
- UL Certified, CE Certified
- Manufactured in Leoch® IATF16949, ISO 9001, ISO 14001 and ISO 45001 certified production facilities

### Discharge Characteristics

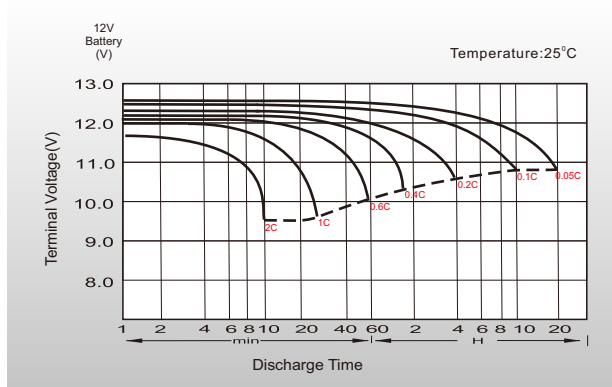

### Float Charging Characteristics

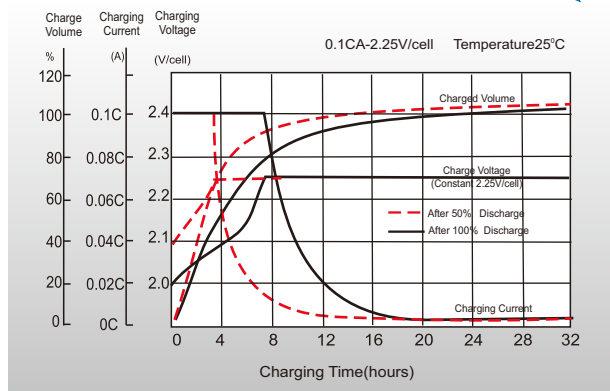

### General Relation of Capacity VS. Storage Time

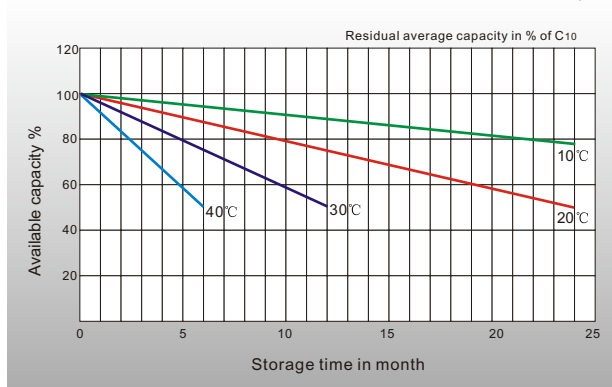

### Effect of Temperature on Long Term Float Life

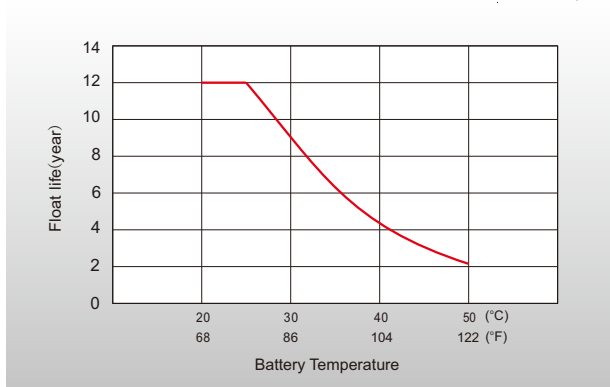

## Sales Offices Worldwide

#### China Sales Office

5th Floor, Xinbaohui Bldg., Nanhai Blvd.,  
Nanshan, Shenzhen, China. 518052  
Tel: +86-755-86036060 (100 lines)  
Fax: +86-755-26067269  
E-mail: export@leoch.com

#### HongKong Sales Office

Workshop C, 33/F, TML Tower, No. 3 Hoi Shing Road,  
Tsuen Wan, New Territories, Hong Kong  
Tel: +852 35786666  
Fax: +44 1452 690125  
E-mail: sales.hk@leoch.com

#### Singapore Sales Office

No. 1 Tech Park Crescent,  
Singapore 638131  
Tel: +65 68636078  
Fax: +65 6863 6079  
Email: sales.sg@Leoch.com

#### Australia Sales Office

2/29 Tarlington Place, Smithfield, NSW 2164  
Australia  
Tel: 02 9756 0950  
E-mail: sales.au@leoch.com

#### North America Sales Office

19751 Descartes  
Foothill Ranch, CA 92610, USA  
Tel: 949-588-5853  
Fax: 949-588-5966  
E-mail: sales@leoch.us

#### UK Sales Office

9B Wheatstone Court, Waterwells, Business Park,  
Gloucester, GL2-2AQ, UK United Kingdom  
Tel: +44(0) 1452 729428 / 1452 729696  
Fax: +44 1452 690125  
E-mail: Sales.Europe@leoch.com

#### EMEA Sales Office

1 Deligiorgi St., 121 31 Athens,  
Greece  
Tel: +30 210 5760318 (2 lines)  
E-mail: support\_EMEA@leoch.com

#### India Sales Office

Shed no. A-53(b), 2nd Stage of Peenya Industrial Area,  
Bangalore North Taluk, Bangalore-560058, India  
Tel: +91-80-23440018/23440019  
Fax: +91-80-23440017  
E-mail: indiasales@leoch.com