

# Starter batteries for motorcycles

## LFPS-X9 [12.8V3Ah]

### Physical Specification

Nominal Voltage		12.8V
Nominal Capacity (10Hr)		3Ah
Dimension	Length	150 ± 2mm (5.91 inches)
	Width	87 ± 2mm (3.43 inches)
	Container Height	105 ± 2mm (4.13 inches)
	Total Height (with Terminal)	105 ± 2mm (4.13 inches)
Weight	Approx 0.61kg (1.34lbs)	

- \* Motorcycle Li-ion battery
- \* Maintenance-free
- \* Powerful 210 cranking amps
- \* Shipped pre-charged and ready to install
- \* Replaces YTX9-BS/YTR9-BS battery

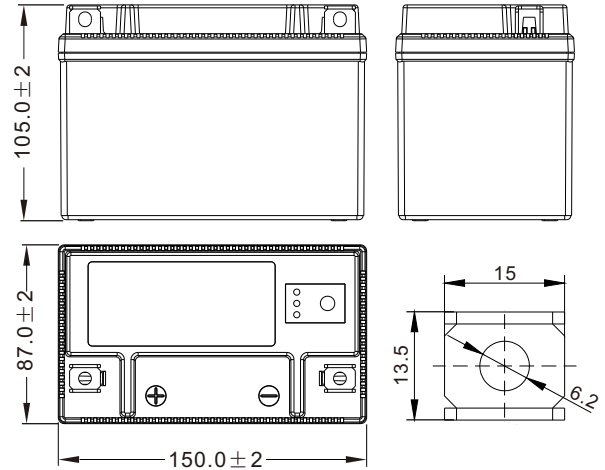

Dimensions (mm)

### Electrical Specification

Rated Capacity	0.1C rate (0.30A)	3.00Ah
	0.5C rate (1.50A)	3.00Ah
	10C rate (30.00A)	2.70Ah
	20C rate (60.00A)	2.70Ah
	30C rate (90.00A)	2.40Ah
Capacity affected by Temperature	40 °C (104 °F)	98%
	25 °C (77 °F)	100%
	0 °C (32 °F)	85%
	-20 °C (-4 °F)	60%
Self Discharge	Approximately 1.5% per month (25°C (77°F))	
Charging Methods	Constant-Voltage Charge:	
	Full Charge	Initial charging current: less than 1.5A Voltage: 14.40 V ~ 14.60 V at 25 °C (77 °F)



### Curve Specification

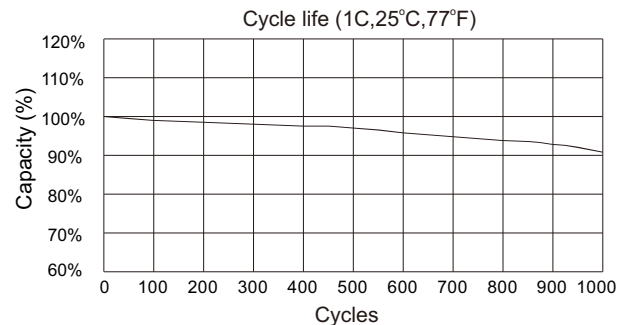
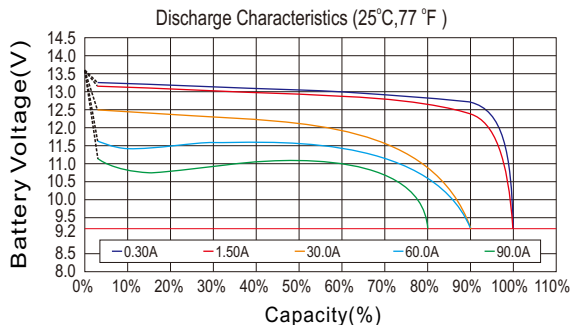

Publication No :LB-LFPS-X9-PD-EN-V1.2-201805

