

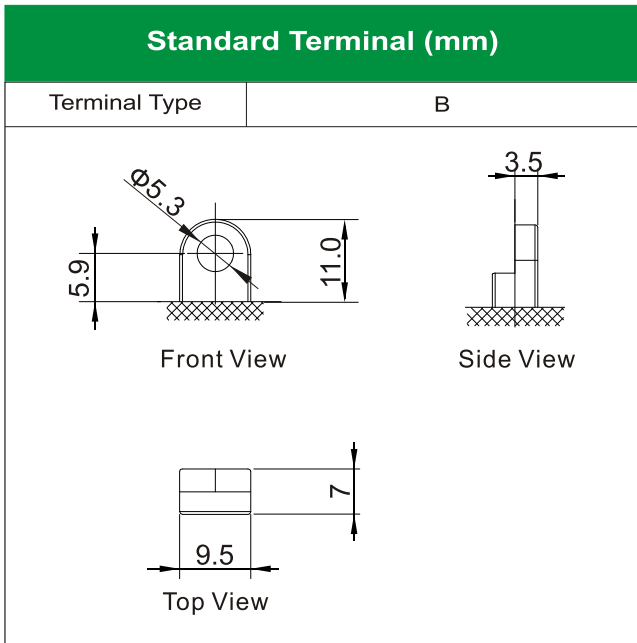

LB3L-B [12V3Ah]

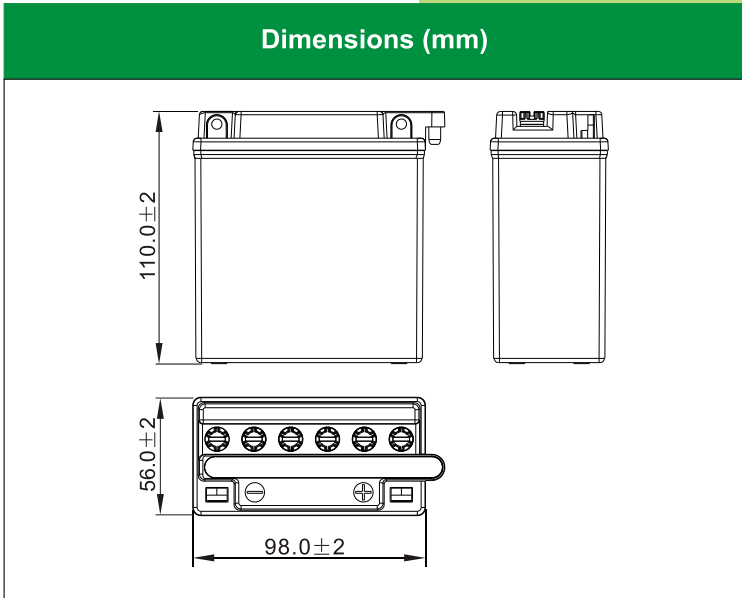

Physical Specification

Nominal Voltage	12V	
Nominal Capacity (10HR)	3Ah	
Dimension	Length	98 ± 2mm (3.86 inches)
	Width	56 ± 2mm (2.20 inches)
	Container Height	110 ± 2mm (4.33 inches)
	Total Height (with Terminal)	110 ± 2mm (4.33 inches)
Weight	Battery(with acid): Approx 1.29kg (2.84lbs)	
	Electrolyte: Approx 0.31kg (0.68lbs)	
<ul style="list-style-type: none"> * High performance and dry charged high quality and flooded battery * Powerful 28 cold cranking amps * Low maintenance * Shipped without battery electrolyte pre-charged and ready to install * Replaces none battery 		

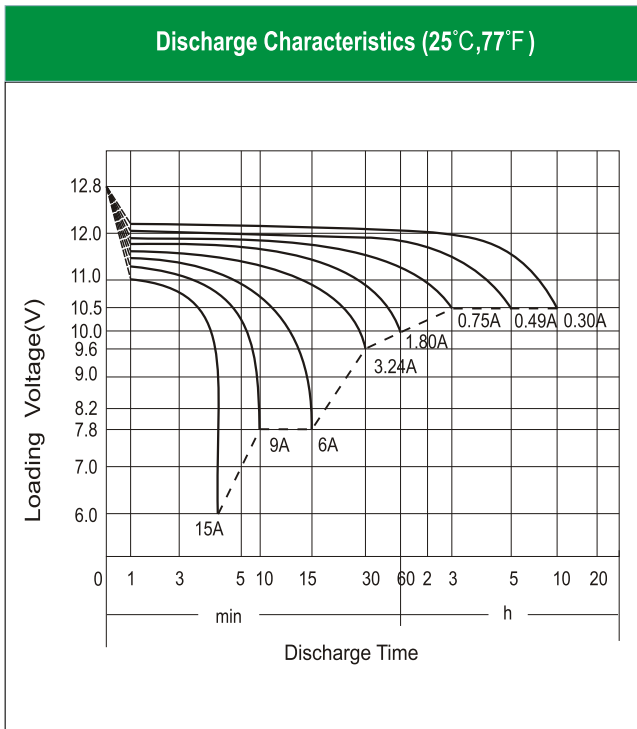

Electrical Specification

Rated Capacity	10 hour rate (0.30A)	3.00Ah
	5 hour rate (0.49 A)	2.46Ah
	2 hour rate (1.05 A)	2.10Ah
	1 hour rate (1.80 A)	1.80Ah
	0.5 hour rate (3.24 A)	1.62Ah
Capacity affected by Temperature	40 °C (104 °F)	106%
	25 °C (77 °F)	100%
	0 °C (32 °F)	86%
	-15 °C (5 °F)	65%
Charging Methods	Full Charge	Constant-Voltage Charge: Initial charging current: less than 0.9A Voltage: 14.40 V ~ 15.00 V at 25 °C (77 °F) Charging time: 16 ~24h Constant-Current Charge: Charging current: 0.3A, when charging voltage up to 15.60V, continue to charge 2h.
	Floating Charge	No limit on Initial charging current Voltage: 13.50 V ~ 13.80 V at 25 °C (77 °F)