

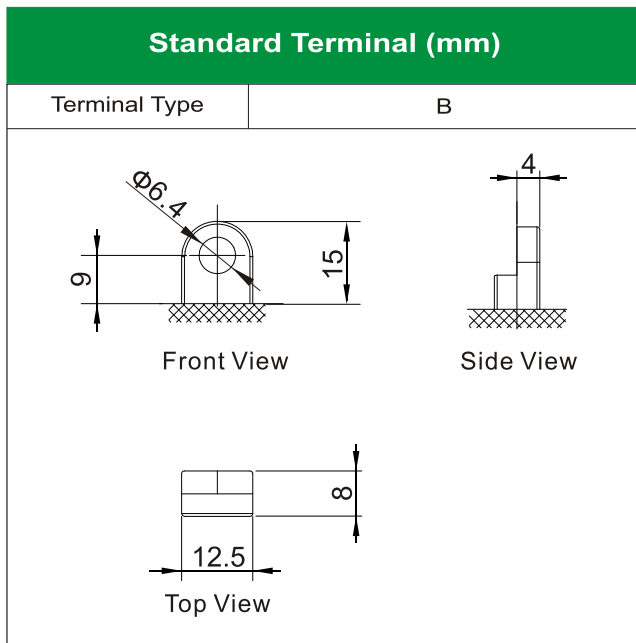

LB10L-B (12V11Ah)

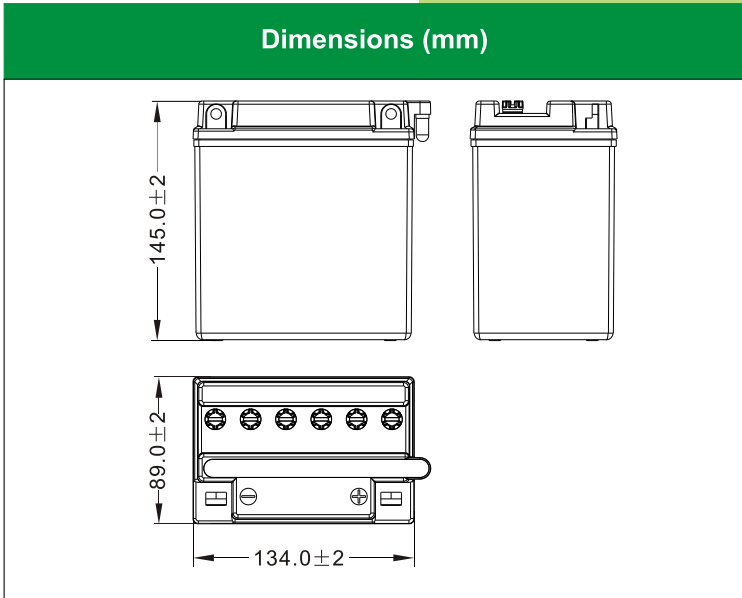

Physical Specification

Nominal Voltage	12V	
Nominal Capacity (10HR)	11Ah	
Dimension	Length	134 ± 2mm (5.28 inches)
	Width	89 ± 2mm (3.50 inches)
	Container Height	145 ± 2mm (5.71 inches)
	Total Height (with Terminal)	145 ± 2mm (5.71 inches)
Weight	Battery(with acid): Approx 3.90kg (8.60lbs)	
	Electrolyte: Approx 1.02kg (2.25lbs)	
<ul style="list-style-type: none"> * High performance and dry charged high quality and flooded battery * Low maintenance * Powerful 130 cold cranking amps * Shipped without battery electrolyte pre-charged and ready to install * Replaces none battery 		

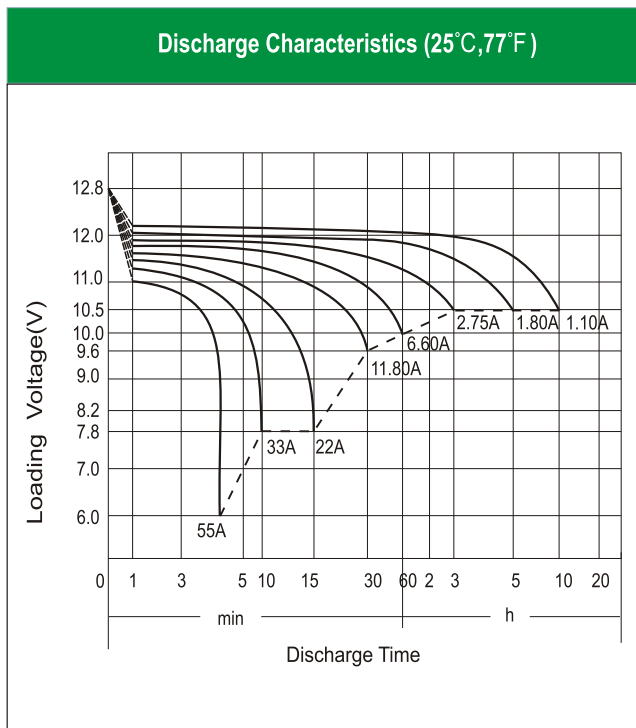

Electrical Specification

Rated Capacity	10 hour rate (1.10A)	11.00Ah
	5 hour rate (1.80 A)	9.02Ah
	2 hour rate (3.85 A)	7.70Ah
	1 hour rate (6.60 A)	6.60Ah
	0.5 hour rate (11.80 A)	5.94Ah
Capacity affected by Temperature	40 °C (104 °F)	106%
	25 °C (77 °F)	100%
	0 °C (32 °F)	86%
	-15 °C (5 °F)	65%
Charging Methods	Full Charge	Constant-Voltage Charge: Initial charging current: less than 3.3A Voltage: 14.40 V ~ 15.00 V at 25 °C (77 °F) Charging time: 16 ~24h Constant-Current Charge: Charging current: 1.1A, when charging voltage up to 15.60V, continue to charge 2h.
	Floating Charge	No limit on Initial charging current Voltage: 13.50 V ~ 13.80 V at 25 °C (77 °F)