

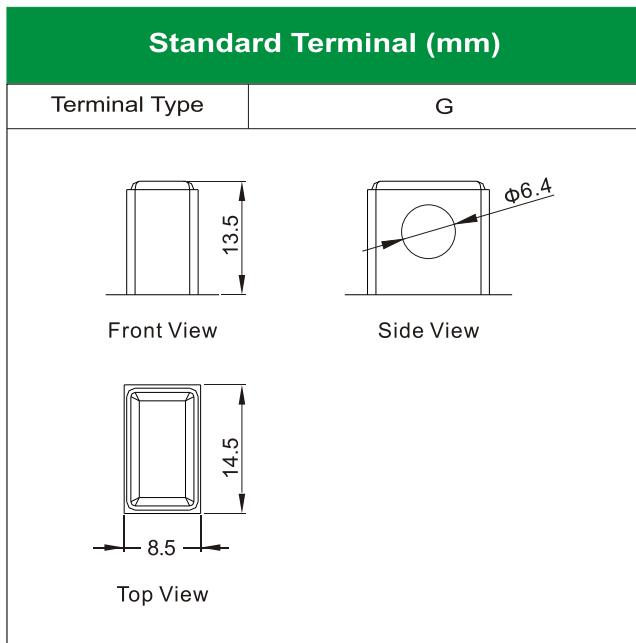

L60-N24AL-B (12V28Ah)

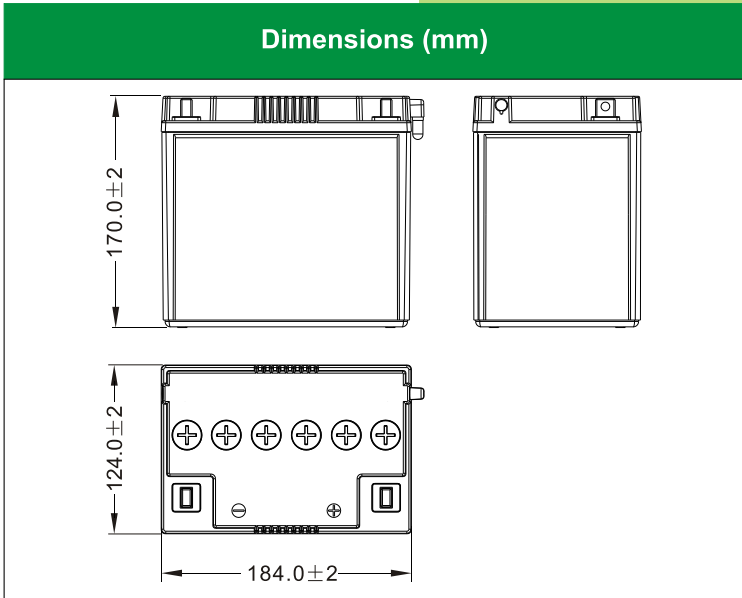

Physical Specification

Nominal Voltage	12V	
Nominal Capacity (10HR)	28Ah	
Dimension	Length	184 ± 2mm (7.24 inches)
	Width	124 ± 2mm (4.88 inches)
	Container Height	170 ± 2mm (6.69 inches)
	Total Height (with Terminal)	170 ± 2mm (6.69 inches)
Weight	Battery(with acid): Approx 7.96kg (17.55lbs) Electrolyte: Approx 2.46kg (5.42lbs)	
<ul style="list-style-type: none"> * High performance and dry charged high quality and flooded battery * Low maintenance * Powerful 280 cold cranking amps * Shipped without battery electrolyte pre-charged and ready to install * Replaces none battery 		

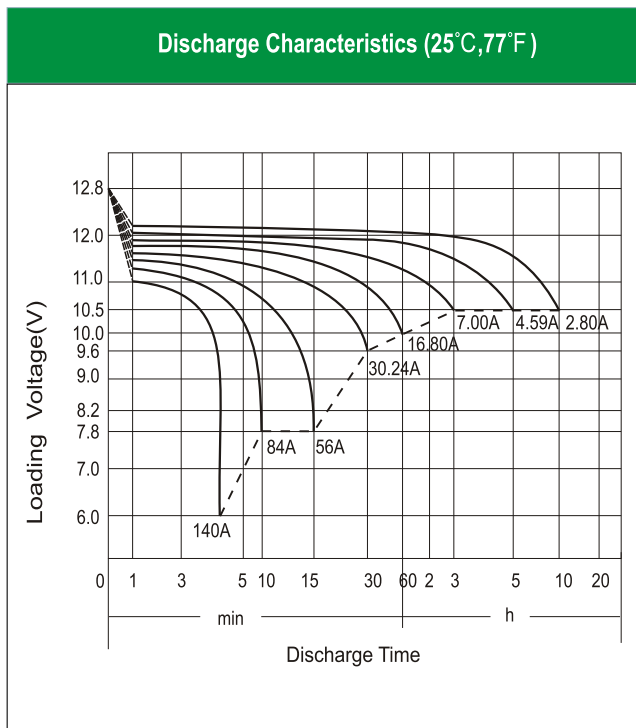

Electrical Specification

Rated Capacity	10 hour rate (2.80A)	28.00Ah
	5 hour rate (4.59 A)	22.96Ah
	2 hour rate (9.80A)	19.60Ah
	1 hour rate (16.80 A)	16.80Ah
	0.5 hour rate (30.24A)	15.12Ah
Capacity affected by Temperature	40 °C (104 °F)	106%
	25 °C (77 °F)	100%
	0 °C (32 °F)	86%
	-15 °C (5 °F)	65%
Charging Methods	Full Charge	Constant-Voltage Charge: Initial charging current: less than 8.4A Voltage: 14.40 V ~ 15.00 V at 25 °C (77 °F) Charging time: 16 ~24h Constant-Current Charge: Charging current: 2.8A, when charging voltage up to 15.60V, continue to charge 2h.
	Floating Charge	No limit on Initial charging current Voltage: 13.50 V ~ 13.80 V at 25 °C (77 °F)