

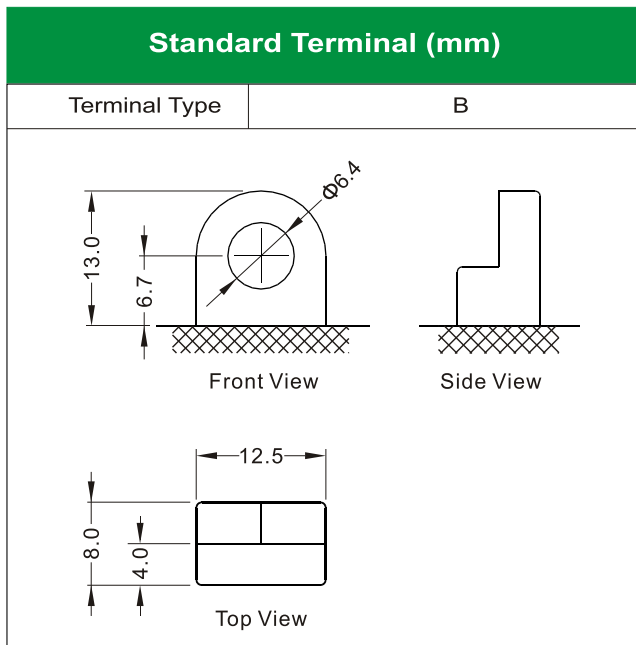

HPG9A-4 [12V9Ah]

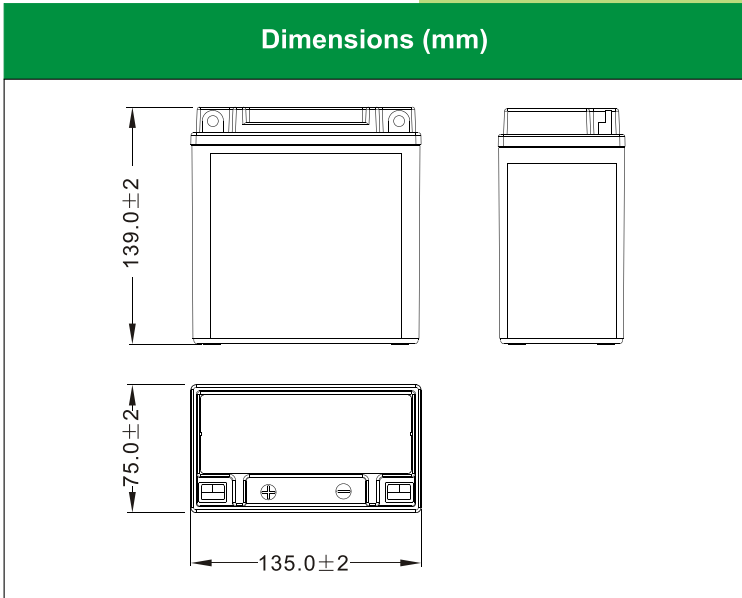

Physical Specification

Nominal Voltage		12V
Nominal Capacity (10HR)		9Ah
Dimension	Length	135 ± 2mm (5.31 inches)
	Width	75 ± 2mm (2.95 inches)
	Container Height	139 ± 2mm (5.47 inches)
	Total Height (with Terminal)	139 ± 2mm (5.47 inches)
Weight	Battery(with acid): Approx 3.07kg (6.77lbs)	
	Electrolyte: Approx 0.65kg (1.43lbs)	

- * 100% leak-proof and spill-proof to 360°
- * Totally Maintenance-free
- * Longer lifespan
- * Lower self discharge
- * Powerful 100 cold cranking amps
- * Shipped pre-charged and ready to install
- * Replaces LT9A-4 battery

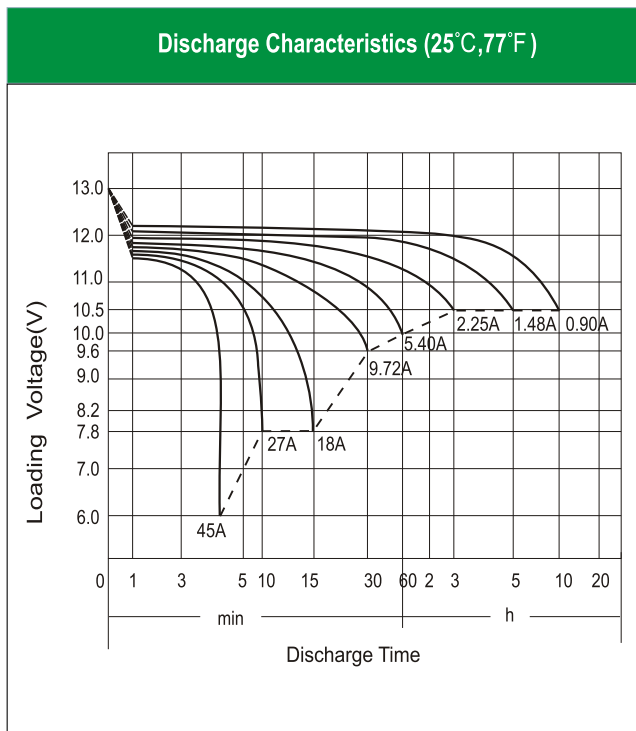

Electrical Specification

Rated Capacity	10 hour rate (0.90 A)	9.0Ah
	5 hour rate (1.48 A)	7.38Ah
	2 hour rate (3.15 A)	6.30Ah
	1 hour rate (5.40 A)	5.40Ah
	0.5 hour rate (9.72 A)	4.86Ah
Capacity affected by Temperature	40 °C (104 °F)	106%
	25 °C (77 °F)	100%
	0 °C (32 °F)	86%
	-15 °C (5 °F)	65%
Charging Methods	Full Charge	Constant-Voltage Charge: Initial charging current: less than 2.7A Voltage: 14.40 V ~ 15.00 V at 25 °C (77 °F) Charging time: 15 ~18h Constant-Current Charge: Charging current: 0.1C ₁₀ =0.90A, when charging voltage up to 14.40V, continue to charge 4h
	Floating Charge	No limit on Initial charging current Voltage: 13.50 V ~ 13.80 V at 25 °C (77 °F)