



AGM CONCEPT GOLF CART BATTERY

Model: DTA12150(12V150AH)

Specification

Nominal Voltage		12V
Rated Capacity (25°C)	20 Hour Rate (7.50A to 10.50V)	150.0Ah
	10 Hour Rate (13.8A to 10.50V)	138.0Ah
	5 Hour Rate (25.6A to 10.50V)	128.0Ah
Reserve Capacity	@25A	318 Minutes
	@75A	86 Minutes
Dimensions	Length	327.0 mm(12.87inches)
	Width	180.0 mm(7.09 inches)
	Height	274.0 mm(10.79inches)
	Total Height	274.0 mm(10.79inches)
Weight		42.1 kg (92.6 lbs)



Characteristics

Capacity Affected by Temperature (20 HR)			Self Discharge @ 25°C(77°F)	Max. Discharge Current@ 25°C(77°F)	Charging @ 25°C(77°F) (Constant Voltage)		Internal Resistance @ 25°C(77°F)	Container Material
0°C (32°F)	25°C (77°F)	40°C (104°F)			Cycle	Float		
85%	100%	102%	<3% of capacity per month	1450A(5S)	14.4~14.7V	13.6~13.8V	3.5mΩ	ABS

Typical Applications

- Golf cart
- Electric vehicle
- Solar
- Wheelchair
- Electric sightseeing car
- Electric scooter
- Electric forklift
- Scraper
- Marine
- Portable Medical device

Battery Structure and Size

T11 Terminal

Unit: mm

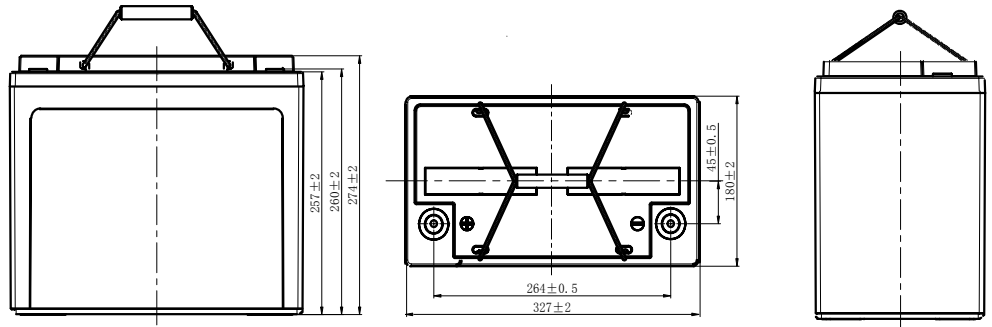
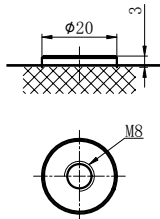

Key features & Benefits

- Maintenance-free sealed construction, spill proof-safe and reliable.
- Strength-enhanced ABS container and compressed plate groups-better vibration and impact resistant.
- Special Lead-Calcium grid design-better corrosion resistant, deep discharge performance, higher capacity and longer cycle life.
- High porosity AGM separator-high oxygen recombination rate to ensure minimum gassing.
- Brass insert terminals-superior conductivity and high rate discharge performance.
- Low internal resistance-high charge acceptance and quick recharge.
- Low self discharge-longer shelf life than conventional batteries.

Performance Characteristics

Charging characteristic (25°C, 77°F)

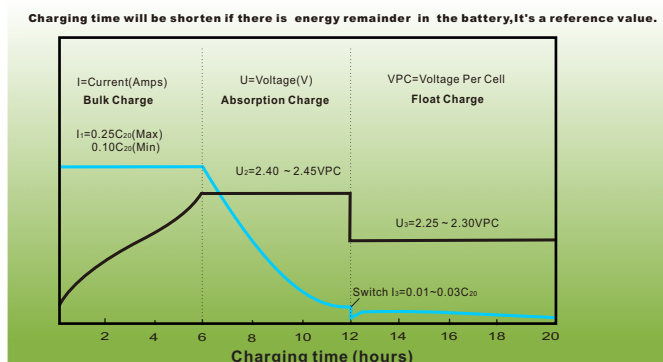

Cycle life in relation to depth of discharge

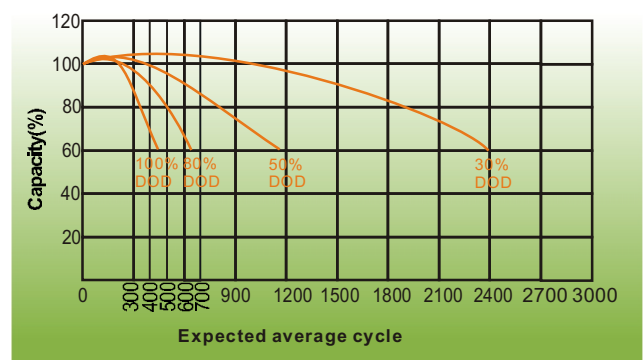

LEOCH INTERNATIONAL TECHNOLOGY LIMITED

China sales office:

Add: 5th Floor, Xinbaohui Bldg., Nanhai Blvd.,
Nanshan, Shenzhen, China. 518052
Tel: +86 755-86036060 (100 lines)
Fax: +86-755-26067269
E-mail: export@leoch.com
Http://www.leoch.com

North America sales office:

Add: 19751 Descartes, Unit A,
Foothill Ranch, CA 92610, USA
Tel: 949-588-5853
Fax: 949-588-5966
E-mail: sales@leoch.us
Http://www.leoch.us

Europe sales office:

Add: 9B Wheatstone Park, Waterwells
Business Park, Gloucester, GL2 2AQ. UK.
Tel: +44(0) 01452 729428
Fax: +44 (0)1452-690125
E-mail: Sales.Europe@leoch.com

HongKong sales office

Add: Unit C, 33/F, TML Tower,
No.3 Hoi Shing Road, Tsuen Wan, N.T.
Tel: +852 3578 6666
Fax: +852 2117 0016
Email: sales.hk@leoch.com

Singapore sales office

Add: NO.1 Tech Park Crescent,
Singapore 638131
Fax: +65 6863 6078
Fax: +65 6863 6079
Email: sales.sg@leoch.com