

# AGM31-100 (12V100Ah)

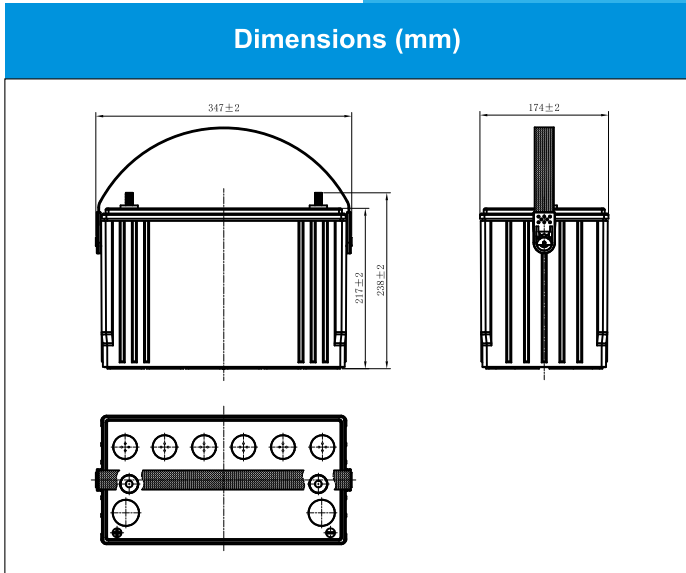

### Physical Specification (mm)

Nominal Voltage		12V
Nominal Capacity(20HR)		100Ah
Dimension	Length	347±2mm(13.66inches)
	Width	174±2mm(6.85inches)
	Container Height	217±2mm(8.54inches)
	Total Height(with Terminal)	238±2mm(9.37inches)
Weight		Approx 31.0Kg(68.36lbs)
Standard Terminal		13
Cell layout		1
Hold-Down		B0
Cell plate qty		/
Case		Black-PP Material
Cover		Black-PP Material
Handle		Black-PP Material

### Electrical Specification

Rated Capacity	20 hour rate(5.0A)	100A
Reserve Capacity		190min
Cold Cranking Performance Amps@0°F(-18°C)		850A

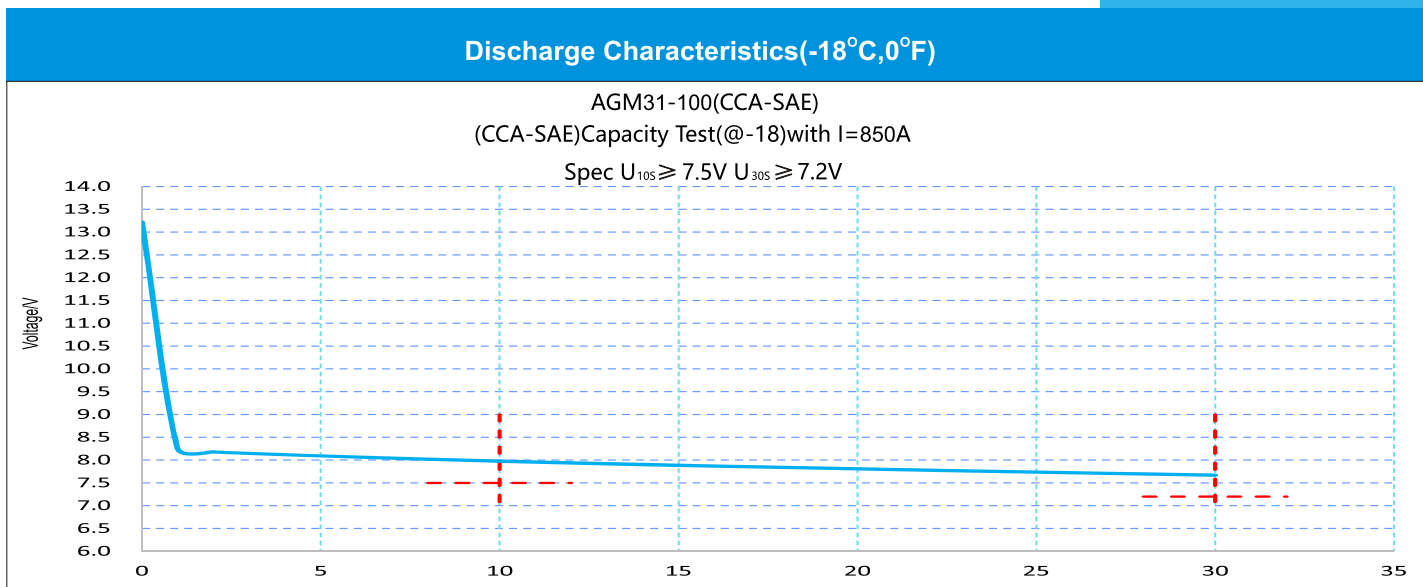
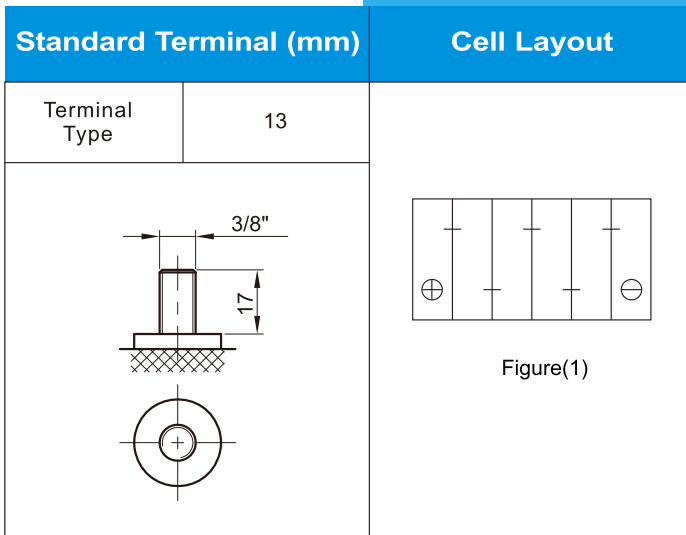

\*Values are subject to variation of +/- 5% in normal manufacturing processes.  
\*Technical specifications and the product line above could be changed without prior notice.