

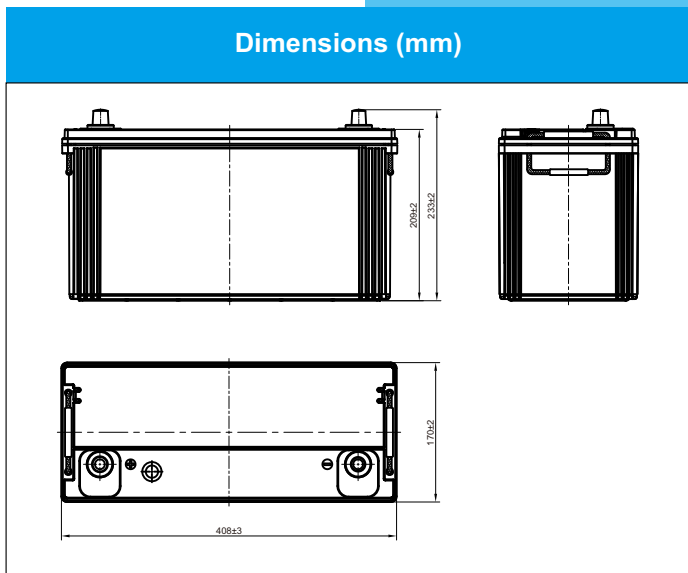

LEOCH BATTERY

6-QW-70(510)-R (12V70Ah)



Physical Specification (mm)

| | | |
|------------------------|-----------------------------|-------------------------------------|
| Nominal Voltage | | 12V |
| Nominal Capacity(20HR) | | 70Ah |
| Dimension | Length | 408±3mm(16.06inches) |
| | Width | 170±2mm(6.69inches) |
| | Container Height | 209±2mm(8.22inches) |
| | Total Height(with Terminal) | 233±2mm(9.17inches) |
| Weight | | Approx22.5Kg(49.61lbs) |
| Acid | | 1.280±0.015g/cm ³ (25°C) |
| Standard Terminal | | 1 |
| Cell layout | | 1 |
| Hold-Down | | B0 |
| Cell plate qty | | / |
| Case | | Black-PP Material |
| Cover | | Black-PP Material |
| Handle | | Black-PP Material |
| QTY/PLT/layer | | / |

Electrical Specification

| | | |
|---|--------------------|--------|
| Rated Capacity | 20 hour rate(3.5A) | 70Ah |
| Reserve Capacity | | 118min |
| Cold Cranking Performance Amps@0°F(-18°C) | | 510A |

Discharge Characteristics(25°C,70°F)

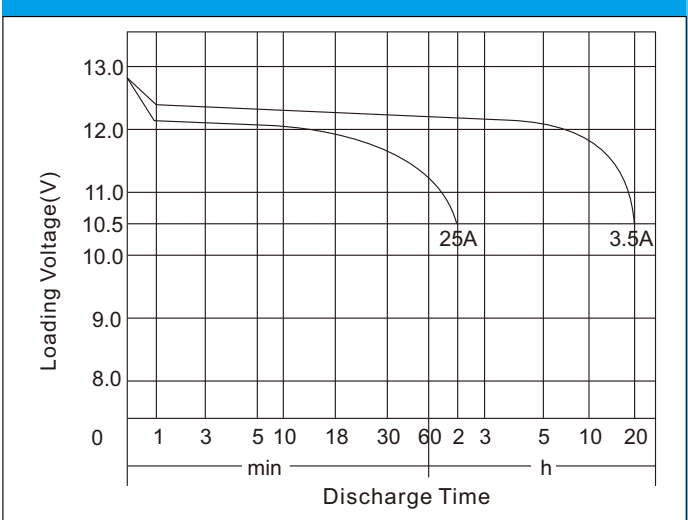

Standard Terminal (mm) Cell Layout

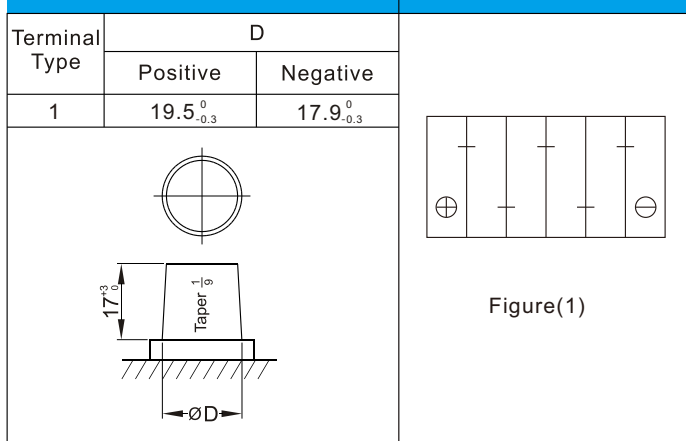

Discharge Characteristics(-18°C,0°F)

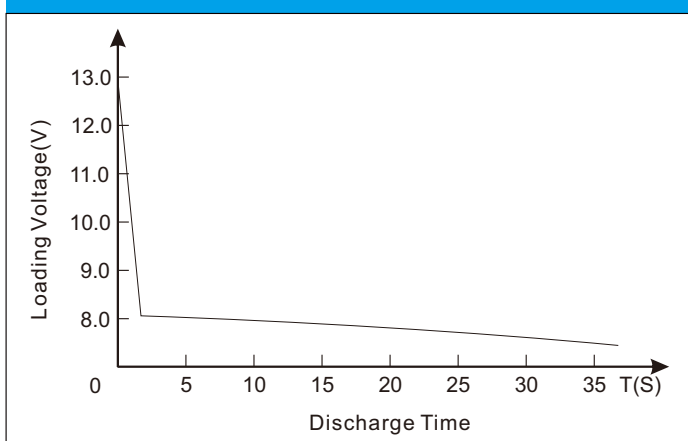

*Values are subject to variation of +/- 5% in normal manufacturing processes.
 *Technical specifications and the product line above could be changed without prior notice.