

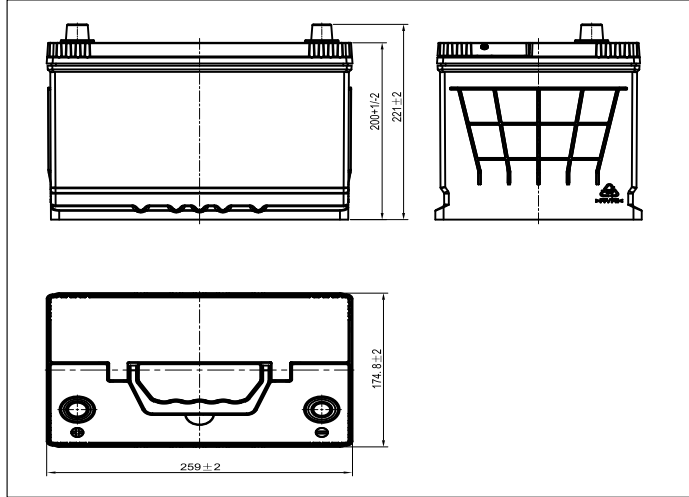

# JIS 48D26R (12V50Ah)



## Dimensions (mm)



## Physical Specification (mm)

Nominal Voltage		12V
Nominal Capacity(20HR)		50Ah
Dimension	Length	259±2mm(10.20inches)
	Width	174.8±2mm(6.88inches)
	Container Height	200+1/-2mm(7.87inches)
	Total Height(with Terminal)	221±2mm(8.70inches)
Weight		Approx15.3Kg(33.74lbs)
Acid		1.280±0.015g/cm <sup>3</sup> (25°C)
Standard Terminal		1
Cell layout		1
Hold-Down		B1
Cell plate qty		/
Case		Black-PP Material
Cover		Black-PP Material
Handle		Black-PP Material
QTY/PLT/layer		/

## Electrical Specification

Rated Capacity	20 hour rate(2.5A)	50Ah
Reserve Capacity		79min
Cold Cranking Performance Amps@0°F(-18°C)		410A

## Discharge Characteristics(25°C,70°F)

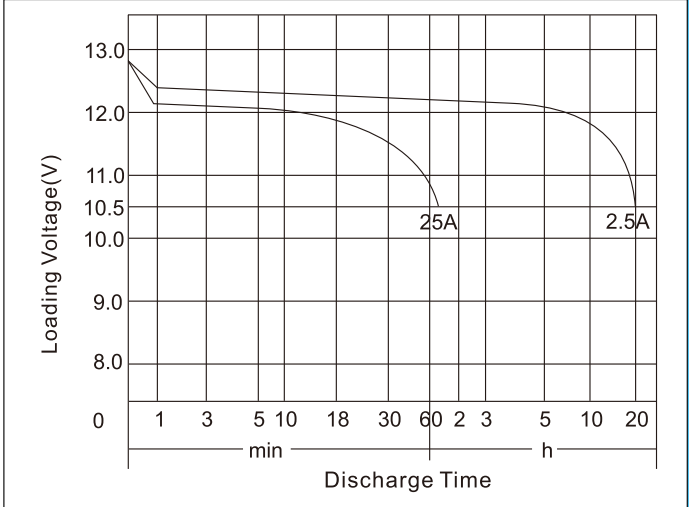

## Standard Terminal (mm)      Cell Layout

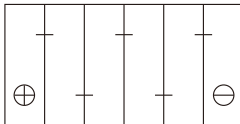
Terminal Type	D		Cell Layout
	Positive	Negative	
1	19.5 <sup>0</sup> <sub>-0.3</sub>	17.9 <sup>0</sup> <sub>-0.3</sub>	

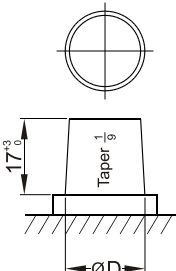

Figure(1)

## Discharge Characteristics(-18°C,0°F)

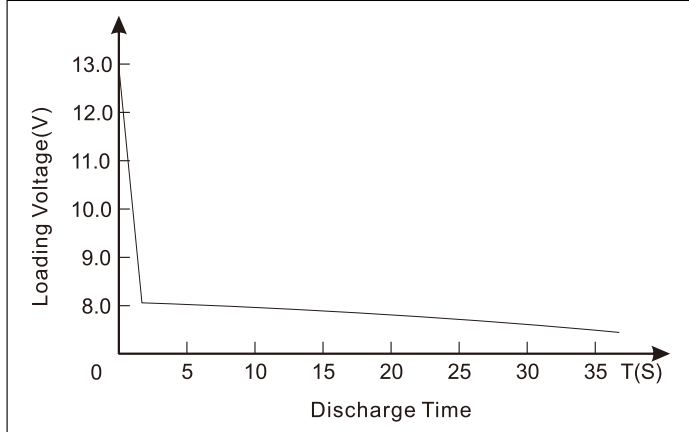

\*Values are subject to variation of +/- 5% in normal manufacturing processes.  
 \*Technical specifications and the product line above could be changed without prior notice.