

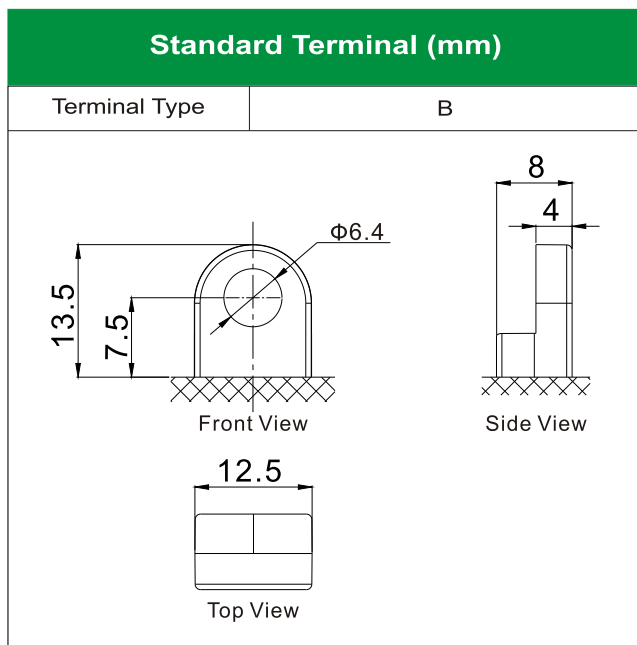

# 12N6.5-3B (12V6.5Ah)

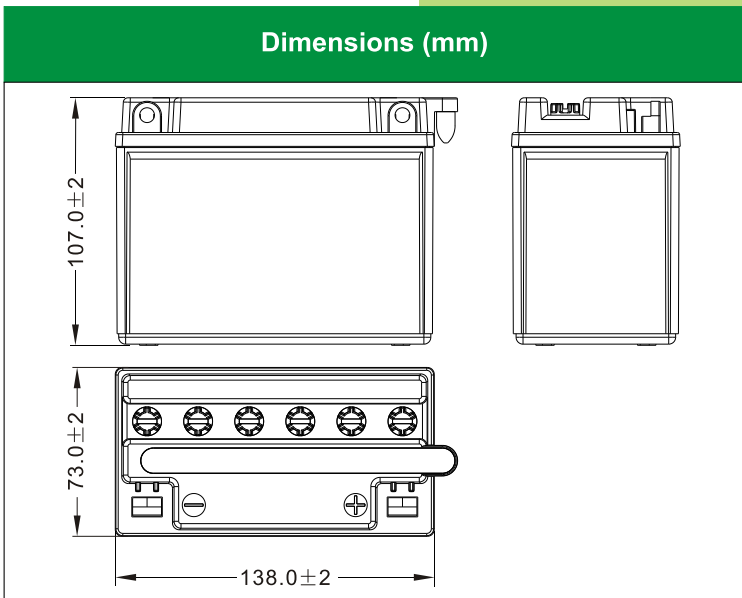

### Physical Specification

Nominal Voltage	12V	
Nominal Capacity (10HR)	6.5Ah	
Dimension	Length	138 ± 2mm (5.43 inches)
	Width	73 ± 2mm (2.87 inches)
	Container Height	107 ± 2mm (4.21 inches)
	Total Height (with Terminal)	107 ± 2mm (4.21 inches)
Weight	Battery(with acid): Approx 2.36kg (5.20lbs) Electrolyte: Approx 0.56kg (1.23lbs)	
<ul style="list-style-type: none"> <li>* High performance and dry charged high quality and flooded battery</li> <li>* Low maintenance</li> <li>* Powerful 55 cold cranking amps</li> <li>* Shipped without battery electrolyte pre-charged and ready to install</li> <li>* Replaces none battery</li> </ul>		

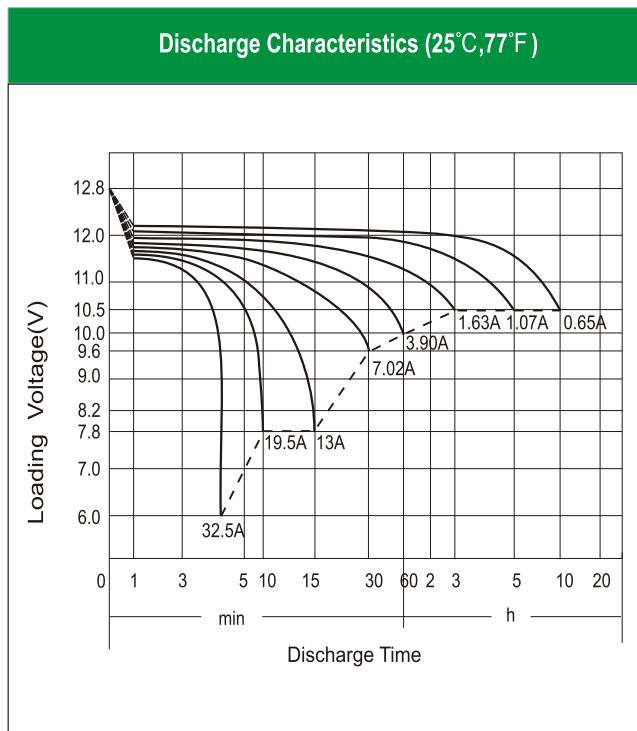

### Electrical Specification

Rated Capacity	10 hour rate (0.65A)	6.50Ah
	5 hour rate (1.07 A)	5.33Ah
	2 hour rate (2.28 A)	4.55Ah
	1 hour rate (3.90 A)	3.90Ah
	0.5 hour rate (7.02 A)	3.51Ah
Capacity affected by Temperature	40 °C (104 °F)	106%
	25 °C (77 °F)	100%
	0 °C (32 °F)	86%
	-15 °C (5 °F)	65%
Charging Methods	Full Charge	Constant-Voltage Charge: Initial charging current: less than 1.95A Voltage: 14.40 V ~ 15.00 V at 25 °C (77 °F) Charging time: 16 ~24h Constant-Current Charge: Charging current: 0.65A, when charging voltage up to 15.60V, continue to charge 2h.
	Floating Charge	No limit on Initial charging current Voltage: 13.50 V ~ 13.80 V at 25 °C (77 °F)