

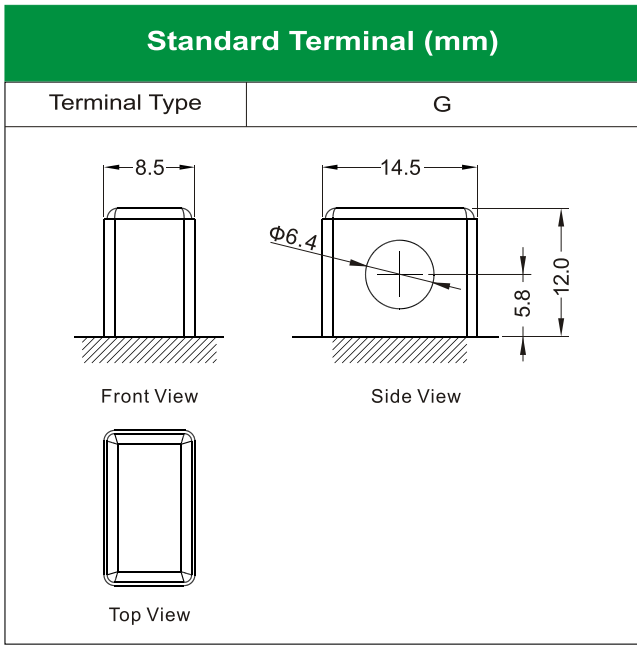

# 12C16A-3A [12V19Ah]

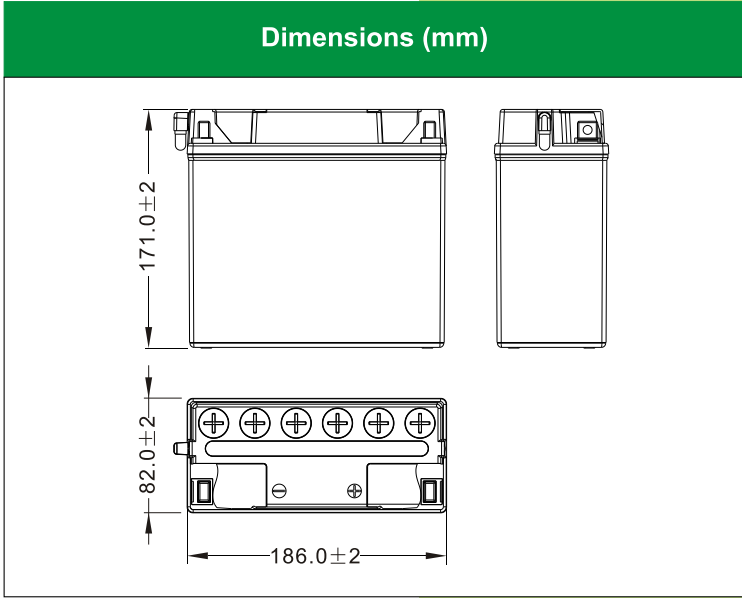

### Physical Specification

Nominal Voltage	12V	
Nominal Capacity (20HR)	19Ah	
Dimension	Length	186 ± 2mm (7.32 inches)
	Width	82 ± 2mm (3.23 inches)
	Container Height	171 ± 2mm (6.73 inches)
	Total Height (with Terminal)	171 ± 2mm (6.73 inches)
Weight	Battery(with acid): Approx 5.93kg (13.08lbs) Electrolyte: Approx 1.43kg (3.15lbs)	
<ul style="list-style-type: none"> <li>* High performance and dry charged high quality and flooded battery</li> <li>* Low maintenance</li> <li>* Powerful 210 cold cranking amps</li> <li>* Shipped without battery electrolyte pre-charged and ready to install</li> <li>* Replaces none battery</li> </ul>		

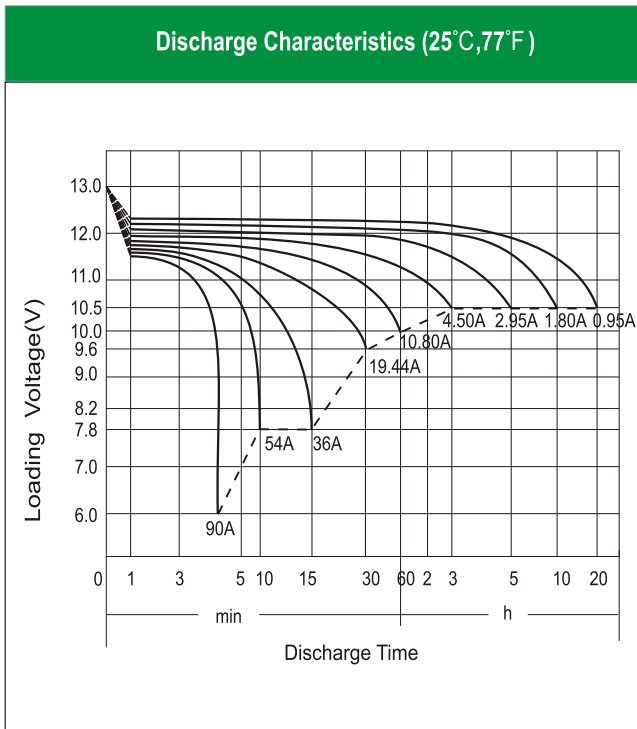

### Electrical Specification

Rated Capacity	20 hour rate (0.95 A)	19.00Ah
	10 hour rate (1.80 A)	18.00Ah
Capacity affected by Temperature	5 hour rate ( 2.95 A)	14.76Ah
	2 hour rate (6.30 A)	12.60Ah
	1 hour rate (10.80 A)	10.80Ah
	0.5 hour rate (19.44 A)	9.72Ah
	40 °C ( 104 °F)	106%
Charging Methods	Full Charge	25 °C ( 77 °F)
		0 °C ( 32 °F)
	Floating Charge	-15 °C ( 5 °F)
		Constant-Voltage Charge: Initial charging current: less than 5.7A Voltage: 14.40 V ~ 15.00 V at 25 °C ( 77 °F) Charging time: 16 ~24h Constant-Current Charge: Charging current: 1.9A, when charging voltage up to 15.60V, continue to charge 2h.
No limit on Initial charging current		
Voltage: 13.50 V ~ 13.80 V at 25 °C ( 77 °F)		